

giorgetti.eu



Collections

Ebanisteria e **arte** del prodotto  
*Cabinetmaking and **art** of the product*

Alta **qualità**  
*High quality*

*Made and Manufactured in*  
**Italy** dal **1898**  
*since*

Oggetti **senza tempo**  
*Timeless objects*

**Unicità** atipica  
*Atypical uniqueness*

Sofisticata **ebanisteria**  
*Sophisticated cabinetmaking*

Innovazione **estetica**  
*Aesthetical innovation*

Vocazione **internazionale**  
*International vocation*

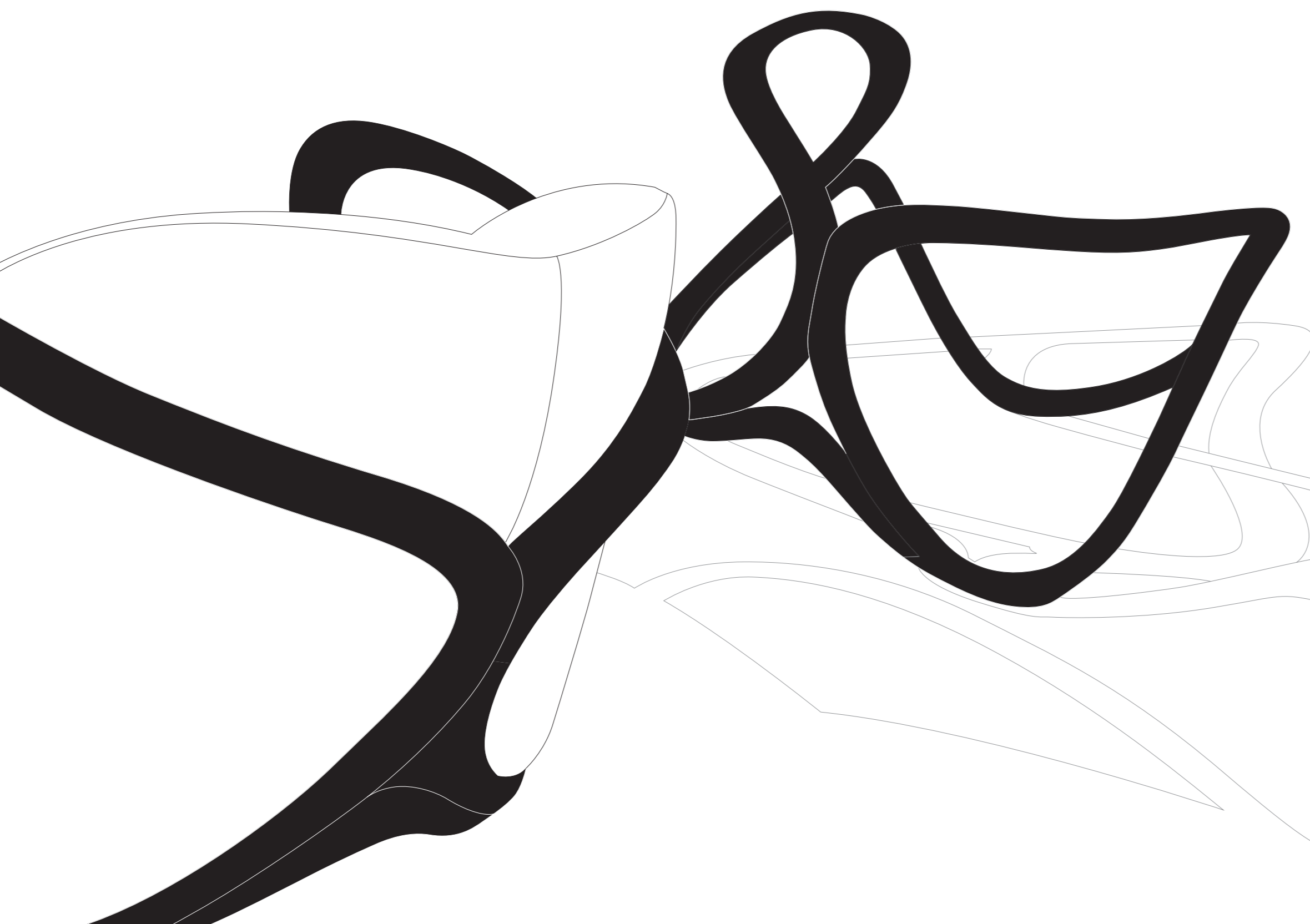

In principio era questo verbo. Un gesto storico, ancestrale, fondatore. Le abili e pazienti mani degli artigiani plasmano il legno negli stabilimenti Giorgetti fin dalla fondazione dell'azienda a Meda, nel cuore della Brianza, nel 1898. Oggi Giorgetti produce collezioni di sedute, tavoli, librerie, letti e complementi firmati da importanti progettisti, alcune delle cui collaborazioni sono nate alla fine degli anni 80 e hanno permesso di creare prodotti funzionali, contemporanei e dallo stile atipico e inconfondibile, in grado di conciliare la più alta tradizione ebanistica con l'impiego di sofisticate tecnologie produttive.

Creatività e design caratterizzano i mobili Giorgetti, dando forma ai materiali più pregiati, come il legno, le pelli, la pietra e il metallo, e rappresentando il "Made and Manufactured in Italy" in tutto il mondo. Un concetto ricco di *heritage* che tanto affascina con l'aggiunta di quel tocco speciale fra passione e stile. Sinonimi in questo caso di amore per il bello e per il buon lavoro, fatto di qualità e di creazioni durevoli, senza tempo.

## L'Arte di plasmare *The art of shaping*

*In the beginning was this verb. A historic, ancestral, founding gesture. The skilled and patient hands of craftsmen shape the wood in the Giorgetti factories since its foundation in Meda, in the heart of Brianza, in 1898. Nowadays Giorgetti produces collections of seats, tables, bookcases, beds and furnishing accessories designed by important architects, some of which collaborations were born in the late 80's and that allowed to create functional, contemporary, unique and atypical products, that are able to reconcile the highest cabinetmaking with the use of sophisticated production technologies.*

*Creativity and design characterize Giorgetti furniture, giving the shape to the most precious materials, such as wood, leather, stone and metal, and representing the "Made and Manufactured in Italy" all over the world. A concept rich in heritage that fascinates with the special touch of passion and style. Synonyms in this case of love for beauty and for the good work, made of quality and timeless creations.*

# INDEX

## RE-EDITIONS

10 | 50250. CHAIR  
12 | DRY. CHAIR

## SEDIE E POLTRONCINE CHAIRS AND SMALL ARMCHAIRS

18 | ADAM.  
20 | ALA.  
22 | ALEXA.  
24 | ALINA.  
26 | ALL AROUND.  
28 | ARABELLA.  
32 | AURA.  
36 | BARON.  
38 | BARRY.  
42 | BRANCA.  
44 | CADDY.  
46 | CLIP.  
48 | COZY.  
50 | DENNY.  
54 | DIANA.  
56 | DORA.  
58 | ELA.  
62 | ELISA.  
64 | EVA.  
68 | GALET.  
70 | GENIUS.  
72 | GIORGINA.  
76 | GRAND TOUR.  
80 | HUG.  
82 | IBLA.  
84 | INA.  
86 | LADY.  
88 | MAGICA.  
92 | MARGOT.  
94 | MOBIUS.  
104 | MOVE.  
106 | MUSA.  
108 | NORAH.  
110 | NORMAL.  
114 | ODE.  
118 | PROGETTI.  
136 | RIPPLE.  
138 | ROI.  
140 | SAHARA.  
144 | SAPHIR.TOPAZE.  
146 | SELECTUS.  
148 | SELENE.  
150 | SINBAD.  
152 | SPRING.  
156 | SWING.  
158 | TEODORA.  
162 | TICHE.  
164 | TILT.  
166 | VENUS.

## DIVANI SOFAS

170 | ADAM.  
176 | AGO.  
178 | ASTOR.  
182 | ATON.  
186 | DHOW.  
190 | DRIVE.  
194 | FABULA.  
198 | GALET.  
202 | MAHARAJA.  
206 | MARTINI.  
208 | MY.  
212 | SOLEMYDAE.  
216 | URBAN.  
218 | VITTORIA.  
222 | WALLY.

## LETI E COMODINI BEDS AND NIGHT TABLES

228 | ALTEA.  
230 | CORIUM.  
232 | FRAME.  
234 | HYPNOS.  
236 | IRA.  
240 | KAO.  
242 | PEGASO.  
244 | REA.  
246 | ARCHIBALD.  
247 | CORIUM.  
248 | FRAME.  
249 | MEA.  
250 | MORFEO.  
251 | OLI 2016.  
252 | ROMEO.  
254 | SYN.

## TAVOLI SCRITTOI E TAVOLINI TABLES WRITING DESKS AND LOW TABLES

260 | ANTEO.  
264 | BIGWIG.  
268 | BLADE.  
272 | CIRCLE.  
274 | DISEGUAL.  
280 | ERASMO.  
284 | FANG.  
292 | GORDON.  
296 | MEMOS.  
302 | MIZAR.  
304 | YLI.  
308 | ALMA.  
312 | EOS.  
314 | ERASMO.  
318 | ION.  
320 | JULIET.  
322 | MOGUL.  
324 | SCRIPTOR.  
330 | STUDIUM.  
332 | TENET.  
344 | TYCOON.  
348 | ZENO.  
352 | AGO.  
354 | ATHENE.  
355 | ATON.  
356 | BLEND.  
358 | DECK.  
360 | DUAL.  
361 | EOS.  
362 | FIT.  
366 | GALET.  
370 | GRAND TOUR.  
372 | LEO.  
374 | LING.  
376 | MAGICA.  
377 | MORFEO.  
378 | OTI.  
380 | REVERSO.  
384 | ROMEO.  
386 | ROUND.  
387 | TUMBLER.

## MOBILI E CASSETTONI SIDEBOARDS AND CHESTS OF DRAWERS

390 | AEI.  
396 | ALFRED.  
400 | BULL.  
402 | CHARLOTTE.  
406 | CLAIR DE LUNE.  
408 | CORIUM.  
412 | DECK.  
414 | DIA.  
416 | EON.  
418 | EON BUFFET.  
420 | FRAME.  
424 | INO.  
428 | JUPITER.  
430 | LIA.  
432 | MOORE.  
438 | MYO.  
440 | NARCISSE.  
442 | NEA.  
444 | NYN.  
446 | OLI 2016.  
450 | ORIGAMI.  
454 | ORO.  
458 | OSCAR.  
460 | PING.  
462 | RIFT.  
464 | THE CABINET OF MEMORIES.  
470 | TOO.  
472 | TOWN.  
480 | VENUS.  
482 | YANG.

## OPEN-AIR

486 | APSARA. SOFA  
492 | GEA. CHAIR  
494 | GEA. SMALL ARMCHAIR  
498 | GEA. SOFA  
502 | GEA. BEACH LOUNGER  
504 | GEA. TABLE  
508 | GEA. COFFEE TABLE  
510 | GEA. PARASOL  
512 | GEA. LAMP  
514 | GEA. TRAY  
516 | GEA. CANDLE-HOLDER

RE-EDITIONS

50250<sup>10</sup>.DRY<sup>12</sup>.

RE-EDITION

---

# 50250

---

ADRIANO E PAOLO SUMAN 1985/2018

RE-EDITION

---

# DRY

---

MASSIMO MOROZZI 1987/2018



SEDIE E POLTRONCINE  
CHAIRS AND SMALL ARMCHAIRS

ADAM<sup>18</sup>. ALA<sup>20</sup>. ALEXA<sup>22</sup>. ALINA<sup>24</sup>.  
ALLAROUND<sup>26</sup>. ARABELLA<sup>28</sup>. AURA<sup>32</sup>.  
BARON<sup>36</sup>. BARRY<sup>38</sup>. BRANCA<sup>42</sup>. CADDY<sup>44</sup>.  
CLIP<sup>46</sup>. COZY<sup>48</sup>. DENNY<sup>50</sup>. DIANA<sup>54</sup>. DORA<sup>56</sup>.  
ELA<sup>58</sup>. ELISA<sup>62</sup>. EVA<sup>64</sup>. GALET<sup>68</sup>. GENIUS<sup>70</sup>.  
GIORGINA<sup>72</sup>. GRANDTOUR<sup>76</sup>.  
HUG<sup>80</sup>. IBLA<sup>82</sup>. INA<sup>84</sup>. LADY<sup>86</sup>. MAGICA<sup>88</sup>.  
MARGOT<sup>92</sup>. MOBIUS<sup>94</sup>. MOVE<sup>104</sup>.  
MUSA<sup>106</sup>. NORAH<sup>108</sup>. NORMAL<sup>110</sup>. ODE<sup>114</sup>.  
PROGETTI<sup>118</sup>. RIPPLE<sup>136</sup>. ROI<sup>138</sup>.  
SAHARA<sup>140</sup>. SAPHIRTOPAZE<sup>144</sup>.  
SELECTUS<sup>146</sup>. SELENE<sup>148</sup>. SINBAD<sup>150</sup>.  
SPRING<sup>152</sup>. SWING<sup>156</sup>. TEODORA<sup>158</sup>.  
TICHE<sup>162</sup>. TILT<sup>164</sup>. VENUS<sup>166</sup>.

---

# ADAM

---

CARLO COLOMBO 2018

---

**ALA**

---

UMBERTO ASNAGO 2017

---

# ALEXA

---

UMBERTO ASNAGO 2018

---

# ALINA

---

ANTONELLO MOSCA 2015

---

# ALL AROUND

---

LUDOVICA + ROBERTO PALOMBA 2018

---

# ARABELLA

---

CARLO GIORGETTI E MASSIMO SCOLARI 2010



cuscinetto da usare come bracciolo  
cushion to be used as an arm

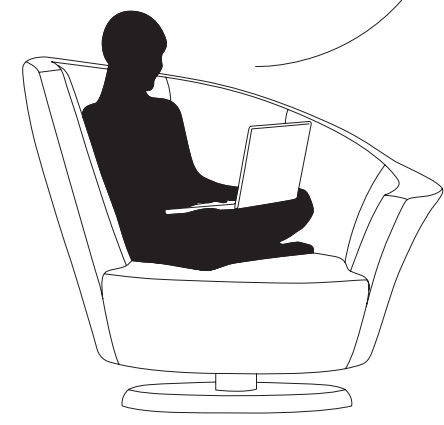

nuovo modo di sedersi: sorprendente varietà di posizioni  
new way of sitting: amazing range of positions



---

# AURA

---

UMBERTO ASNAGO 2014/2015



---

# BARON

---

ROBERTO LAZZERONI 2017

---

# BARRY

---

ANTONELLO MOSCA 2011

BARRY

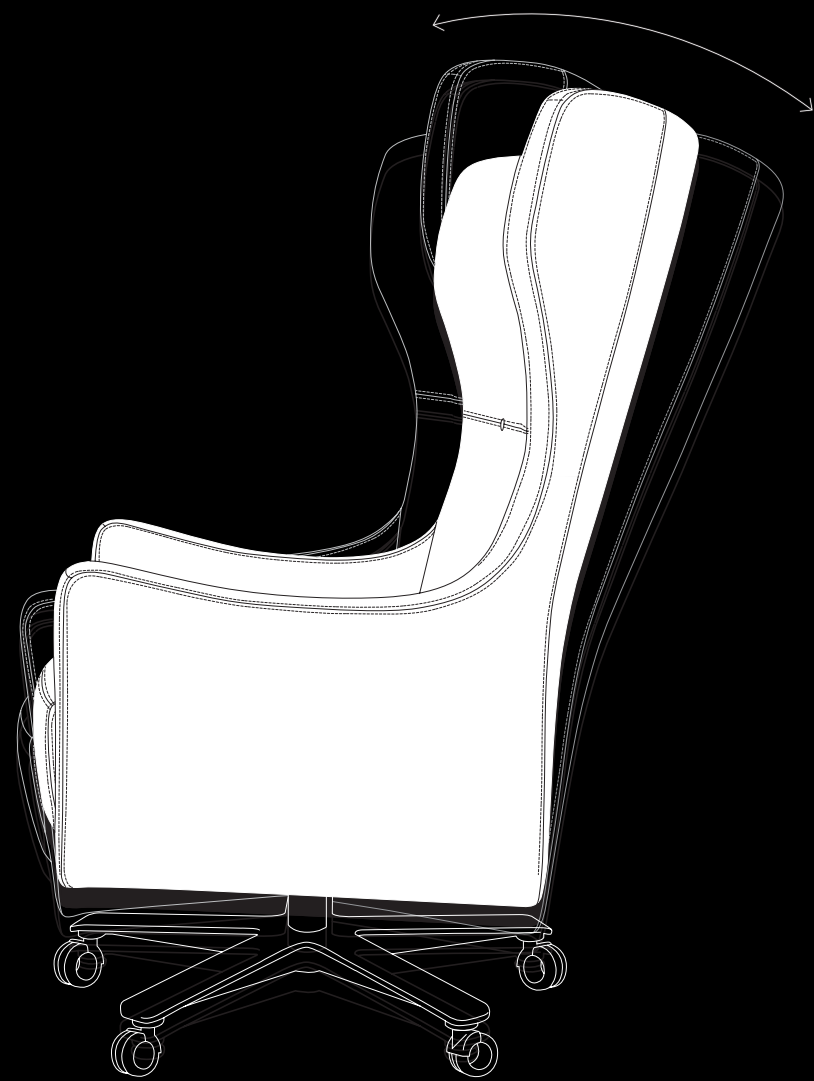

40

41

sistema basculante per favorire l'ergonomia tilting mechanism to support ergonomics

---

# BRANCA

---

ALESSIO DE FRANCESCO 2016

---

# CADDY

---

CARLO COLOMBO 2015

---

# CLIP

---

M2ATELIER 2018

---

# COZY

---

UMBERTO ASNAGO 2015

---

DENNY

---

LAURA SILVESTRINI 2011



---

# DIANA

---

CARLO COLOMBO 2013

---

# DORA

---

MASSIMO SCOLARI 2007/2009

---

ELA

---

CHI WING LO 2004

ELA

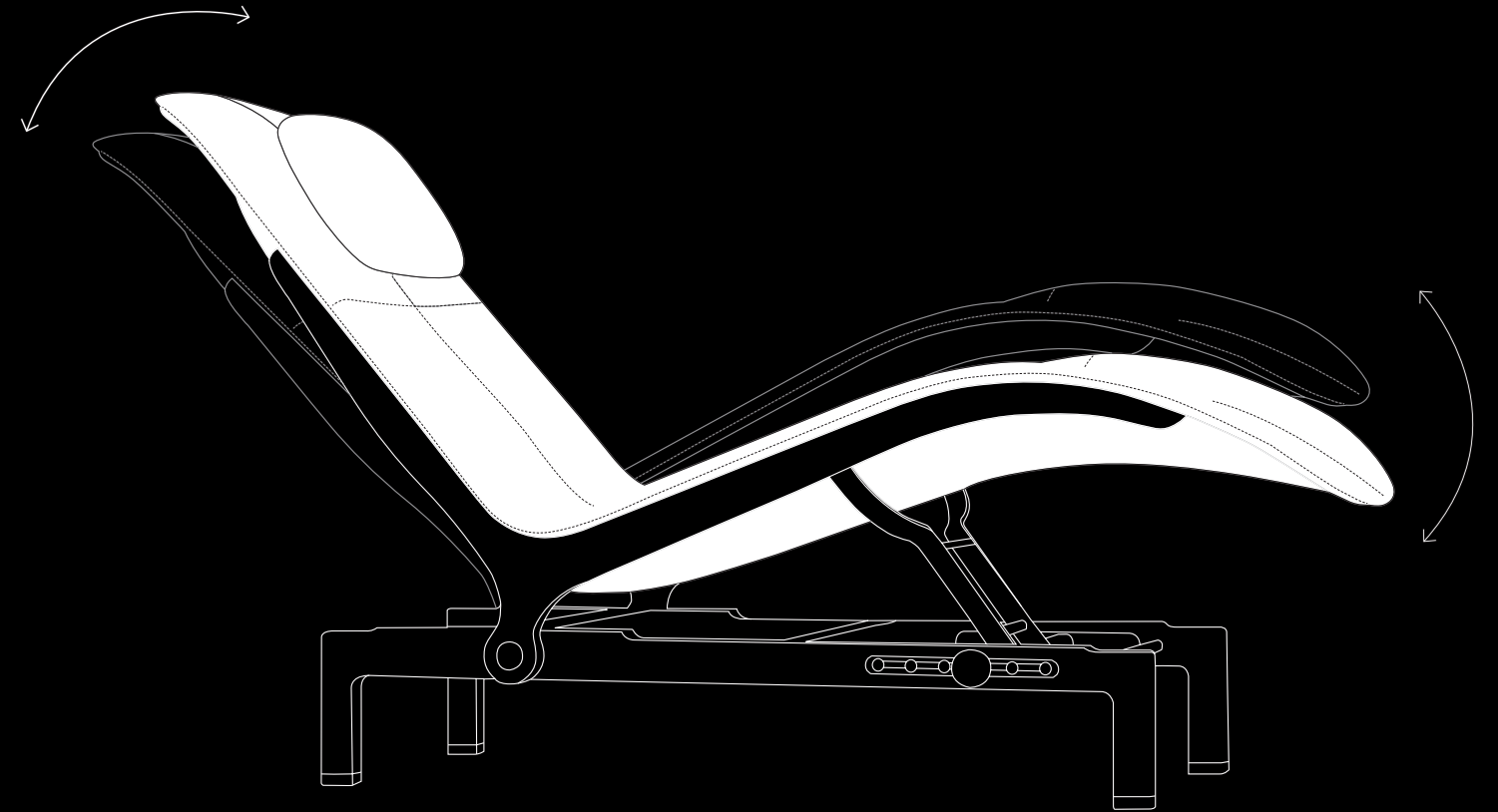

60

61

*inclinazione seduta regolabile in sei differenti posizioni reclining seat adjustable with six different positions*

---

# ELISA

---

CARLO COLOMBO 2015

---

# EVA

---

CARLO COLOMBO 2014



---

# GALET

---

LUDOVICA + ROBERTO PALOMBA 2017

---

# GENIUS

---

ROBERTO LAZZERONI 2014

---

# GIORGINA

---

ANTONELLO MOSCA 1992



---

# GRAND TOUR

---

PAOLO SUMAN 2018



---

# HUG

---

ROSSELLA PUGLIATTI 2013

---

# IBLA

---

ROBERTO LAZZERONI 2016

---

INA

---

CHI WING LO 2000/2012

---

# LADY

---

UMBERTO ASNAGO 2015

---

# MAGICA

---

TOSHIYUKI KITA 2013



---

# MARGOT

---

ANTONELLO MOSCA 2008/2009

---

# MOBIUS

---

UMBERTO ASNAGO 2011/2016









---

# MOVE

---

ROSSELLA PUGLIATTI 2014

---

# MUSA

---

ANTONELLO MOSCA 2008

---

# NORAH

---

M2ATELIER 2015

---

# NORMAL

---

MASSIMO SCOLARI 2003/2006



---

# ODE

---

CHI WING LO 2012/2018



---

# PROGETTI

---

CENTRO RICERCHE GIORGETTI 1987/2009









# PROGETTI BLOSSOM

CENTRO RICERCHE GIORGETTI 2009

originale cucitura con inserto in pelle  
sulla parte interna dello schienale  
original stitched covering with a leather insert  
on the inside of the backrest

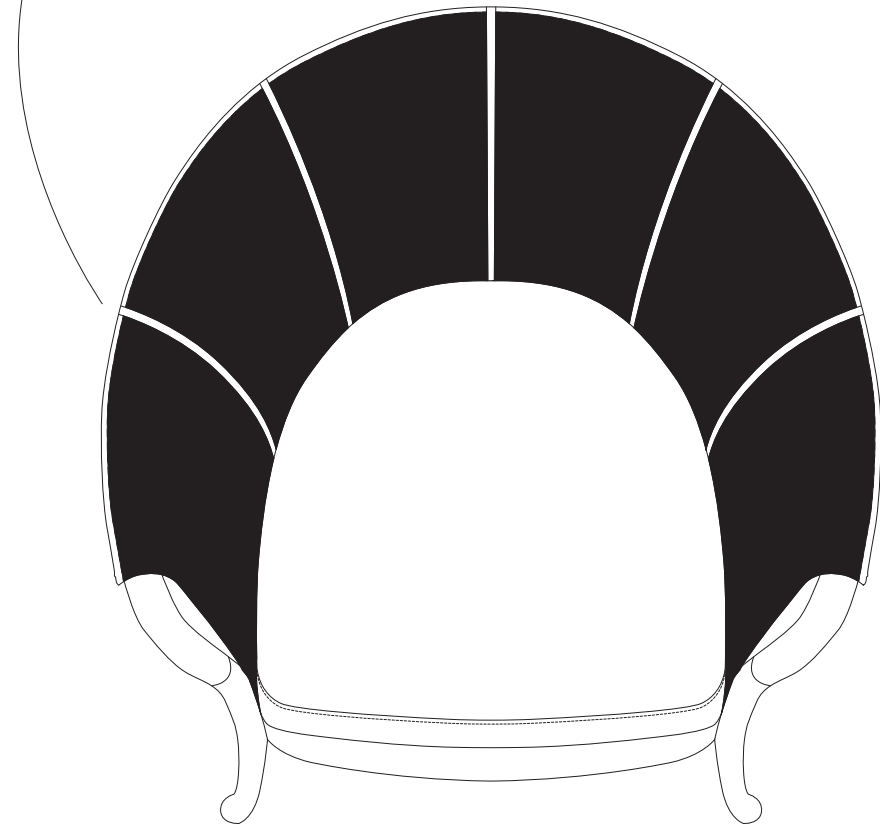

# PROGETTI FASHION

CENTRO RICERCHE GIORGETTI 2017





---

# PROGETTI SENSE

---

CENTRO RICERCHE GIORGETTI 2017

---

# RIPPLE

---

LUDOVICA + ROBERTO PALOMBA 2017

---

# ROI

---

CHI WING LO 2008

---

# SAHARA

---

ROSSELLA PUGLIATTI 2017



---

# TOPAZE

---

MOSCA 2010

---

# SELECTUS

---

LÉON KRIER 2004

---

# SELENE

---

ROBERTO LAZZERONI 2015

---

# SINBAD

---

ROBERTO LAZZERONI 2018

---

SPRING

---

MASSIMO SCOLARI 1992

SPRING

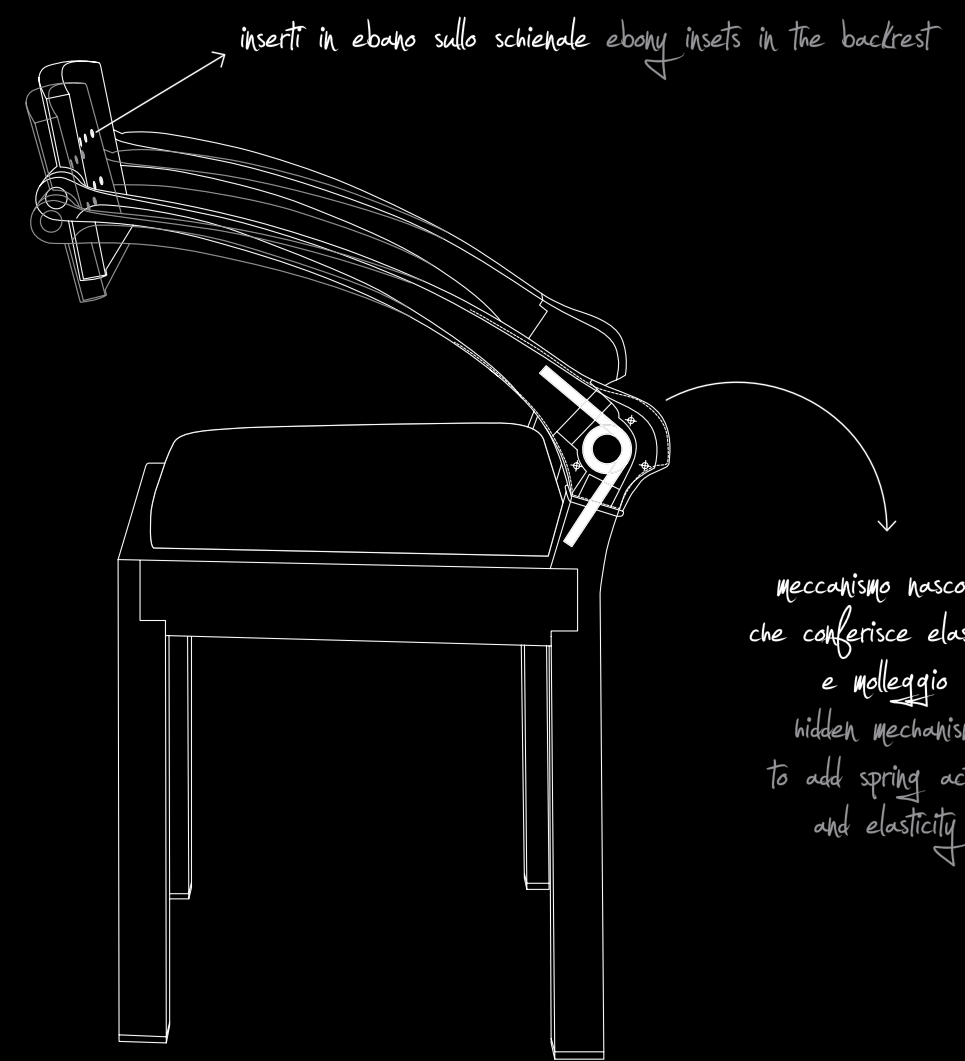

154  
155

---

# SWING

---

CARLO COLOMBO 2015

---

# TEODORA

---

MASSIMO SCOLARI 2009

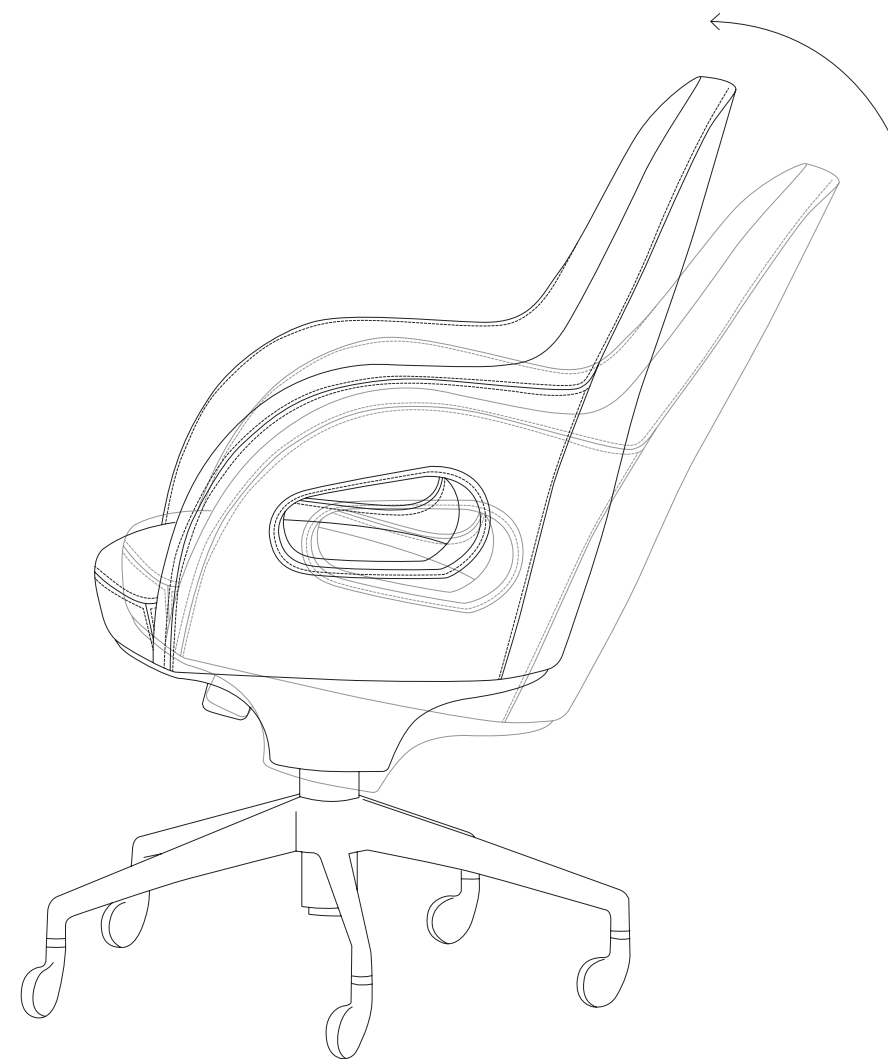

leva per regolare l'altezza e basculante per ottenere la posizione corretta del corpo  
lever to adjust the height and tilt to favour a correct body position

---

# TICHE

---

CARLO COLOMBO 2014

---

# TILT

---

M2ATELIER 2015

---

# VENUS

---

ROBERTO LAZZERONI 2014

---

DIVANI  
SOFAS

---

ADAM<sup>170</sup>. AGO<sup>176</sup>. ASTOR<sup>178</sup>. ATON<sup>182</sup>.  
DHOW<sup>186</sup>. DRIVE<sup>190</sup>. FABULA<sup>194</sup>.  
GALET<sup>198</sup>. MAHARAJA<sup>202</sup>.  
MARTINI<sup>206</sup>. MY<sup>208</sup>. SOLEMYIDAE<sup>212</sup>.  
URBAN<sup>216</sup>. VITTORIA<sup>218</sup>. WALLY<sup>222</sup>.

---

# ADAM

---

CARLO COLOMBO 2018





---

AGO

---

CARLO COLOMBO 2014

---

176  
177

---

---

ASTOR

---

ANTONELLO MOSCA 2005



---

# ATON

---

CARLO COLOMBO 2014



---

DHOW

---

ANDREI MUNTEANU 2011



---

# DRIVE

---

CARLO COLOMBO 2016



---

# FABULA

---

UMBERTO ASNAGO 2012/2014



---

# GALET

---

LUDOVICA + ROBERTO PALOMBA 2018



---

# MAHARAJA

---

ANTONELLO MOSCA 2010



---

# MARTINI

---

ROSSELLA PUGLIATTI 2015

---

MY

---

ROSSELLA PUGLIATTI 2014



---

# SOLEMYIDAE

---

ROSSELLA PUGLIATTI 2013



---

# URBAN

---

CARLO COLOMBO 2015

---

# VITTORIA

---

CARLO COLOMBO 2013



---

# WALLY

---

ANTONELLO MOSCA 2005



---

LETTI E COMODINI  
BEDS AND NIGHT-TABLES

---

ALTEA<sup>228</sup>.CORIUM<sup>230</sup>.  
FRAME<sup>232</sup>.HYPNOS<sup>234</sup>.IRA<sup>236</sup>.  
KAO<sup>240</sup>.PEGASO<sup>242</sup>.REA<sup>244</sup>.  
ARCHIBALD<sup>246</sup>.CORIUM<sup>247</sup>.  
FRAME<sup>248</sup>.MEA<sup>249</sup>.MORFEO<sup>250</sup>.  
OLI2016<sup>251</sup>.ROMEO<sup>252</sup>.SYN<sup>254</sup>.

---

# ALTEA

---

CARLO COLOMBO 2013

---

# CORIUM

---

UMBERTO ASNAGO 2012

---

# FRAME

---

CARLO COLOMBO 2017

---

# HYPNOS

---

UMBERTO ASNAGO 2017

---

# IRA

---

CHI WING LO 2012



---

**KAO**

---

CHI WING LO 2009

---

# PEGASO

---

ROBERTO LAZZERONI 2018

---

REA

---

CHI WING LO 2005

---

# ARCHIBALD

---

ROBERTO LAZZERONI 2014

---

# CORIUM

---

UMBERTO ASNAGO 2012

---

# FRAME

---

CARLO COLOMBO 2017

---

# MEA

---

CHI WING LO 2009

---

# MORFEO

---

CARLO COLOMBO 2013

---

# OLI 2016

---

CHI WING LO 1995/2016

---

# ROMEO

---

ROBERTO LAZZERONI 2018

SYN  
CHI WING LO 2012

TAVOLI SCRITTOI E TAVOLINI  
TABLES WRITING DESKS AND LOW TABLES

ANTEO.<sup>260</sup> BIGWIG.<sup>264</sup> BLADE.<sup>268</sup>  
CIRCLE.<sup>272</sup> DISEGUAL.<sup>274</sup> ERASMO.<sup>280</sup>  
FANG.<sup>284</sup> GORDON.<sup>292</sup> MEMOS.<sup>296</sup>  
MIZAR.<sup>302</sup> YLI.<sup>304</sup> ALMA.<sup>308</sup> EOS.<sup>312</sup>  
ERASMO.<sup>314</sup> ION.<sup>318</sup> JULIET.<sup>320</sup> MOGUL.<sup>322</sup>  
SCRIPTOR.<sup>324</sup> STUDIUM.<sup>330</sup> TENET.<sup>332</sup>  
TYCOON.<sup>344</sup> ZENO.<sup>348</sup> AGO.<sup>352</sup>  
ATHENE.<sup>354</sup> ATON.<sup>355</sup> BLEND.<sup>356</sup>  
DECK.<sup>358</sup> DUAL.<sup>360</sup> EOS.<sup>361</sup> FIT.<sup>362</sup> GALET.<sup>366</sup>  
GRANDTOUR.<sup>370</sup> LEO.<sup>372</sup> LING.<sup>374</sup>  
MAGICA.<sup>376</sup> MORFEO.<sup>377</sup> OTI.<sup>378</sup> REVERSO.<sup>380</sup>  
ROMEO.<sup>384</sup> ROUND.<sup>386</sup> TUMBLER.<sup>387</sup>

---

# ANTEO

---

CARLO COLOMBO 2014



---

# BIG WIG

---

ROBERTO LAZZERONI 2017



---

264  
265

---



---

# BLADE

---

UMBERTO ASNAGO 2017



---

# CIRCLE

---

UMBERTO ASNAGO 2015

---

# DISEGUAL

---

UMBERTO ASNAGO 2018





---

# ERASMO

---

MASSIMO SCOLARI 2010



---

280  
281

---



---

FANG

---

DESIGN MVW 2013











---

---





---

# MIZAR

---

ROBERTO LAZZERONI 2015

---

**YLI**

---

CHI WING LO 2012



---

# ALMA

---

PAMELA AMINE 2017





---

# ERASMO

---

MASSIMO SCOLARI 2009

forma a foglia del piano  
calibra le distanze tra i due lati opposti  
leaf shape of the top  
to gauge the distances between the two opposite sides

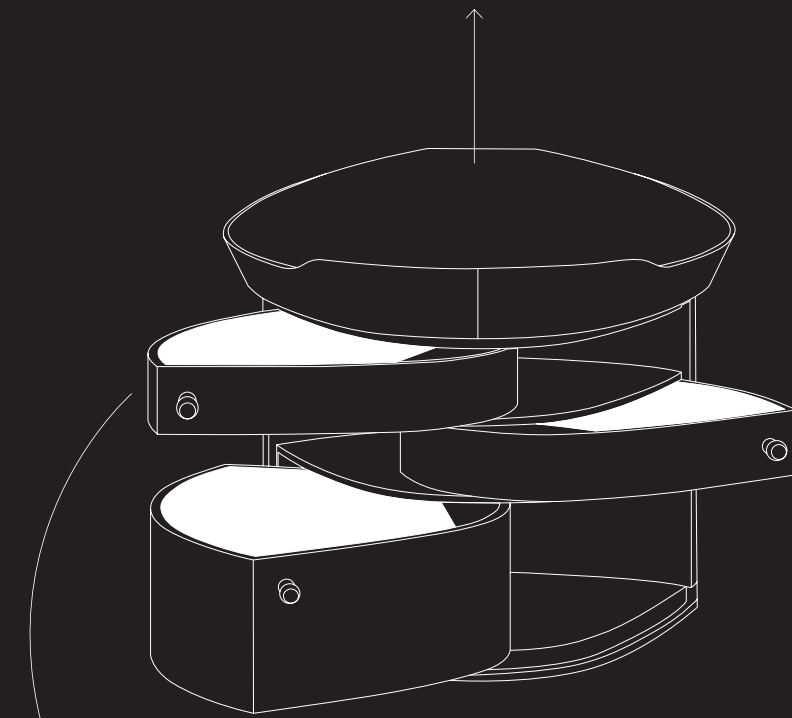

tre cassetti con sistema di apertura indipendente a 360° gradi  
three drawers with independent 360° opening system

cassetti estraibili su entrambi i lati  
extractable drawers on either sides

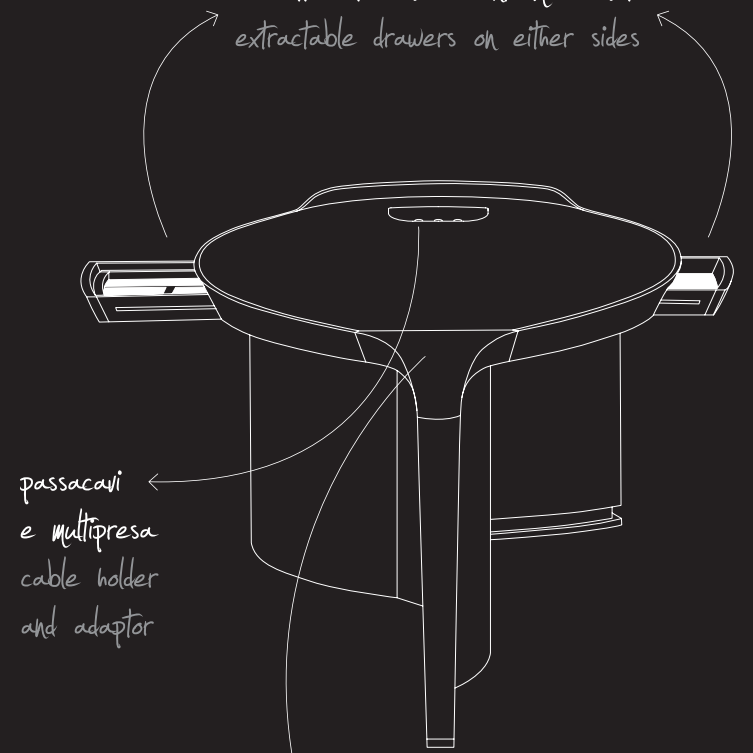

passacavi e multipresa  
cable holder and adaptor

gamba unica e raccordo in noce  
canaletto naturale  
one leg and join  
in walnut canaletto wood

---

# ION

---

CHI WING LO 2012

---

# JULIET

---

ROBERTO LAZZERONI 2018

---

# MOGUL

---

ROBERTO LAZZERONI 2017

---

# SCRIPTOR

---

LÉON KRIER 2004/2007



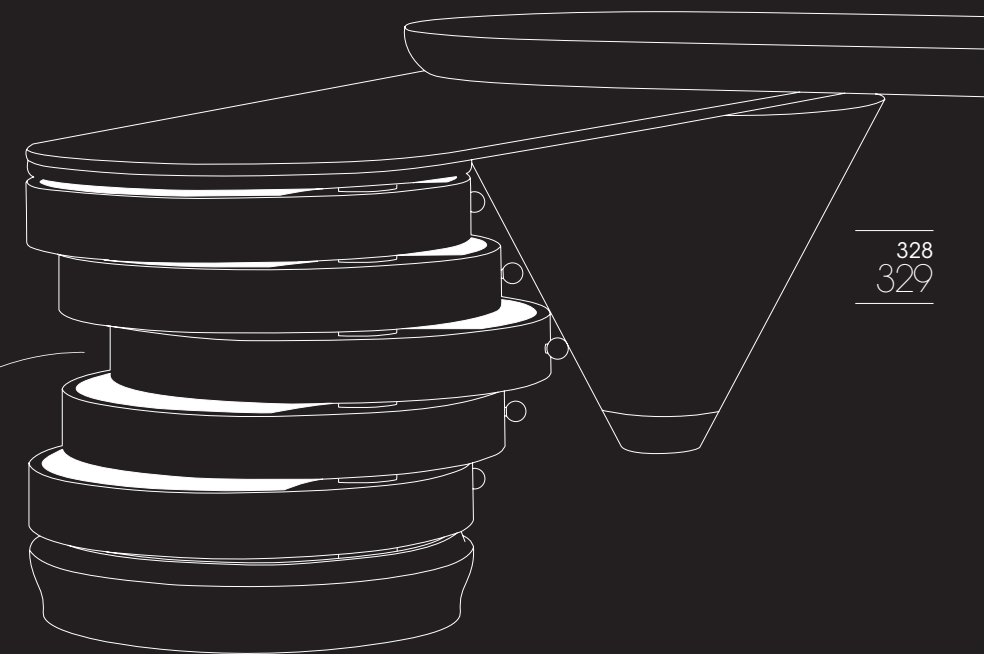

cassettiera cilindrica a 5 cassetti con sistema di apertura indipendente a 180 gradi  
cylindrical chest with 5 drawers that have independent 180° opening system

---

# STUDIUM

---

UMBERTO ASNAGO 2015

---

# TENET

---

MASSIMO SCOLARI 2017/2018











---

# TYCOON

---

ROBERTO LAZZERONI 2014



---

# ZENO

---

MASSIMO SCOLARI 1994



---

AGO

---

CARLO COLOMBO 2014

---

352  
353

---

---

# ATHENE

---

ANTONELLO MOSCA 1997/2009

---

# ATON

---

CARLO COLOMBO 2014

---

# BLEND

---

CARLO COLOMBO 2016

---

# DECK

---

ROSSELLA PUGLIATTI 2015

---

# DUAL

---

CENTRO RICERCHE GIORGETTI 2007

---

# EOS

---

CHI WING LO 2003/2012

---

# FIT

---

GIANCARLO BOSIO E CENTRO RICERCHE GIORGETTI 2018



---

# GALET

---

LUDOVICA + ROBERTO PALOMBA 2017



---

# GRAND TOUR

---

PAOLO SUMAN 2018

---

LEO

---

LAURA SILVESTRINI 2011

---

# LING

---

DESIGN MVW 2013

---

# MAGICA

---

TOSHIYUKI KITA 2013

---

# MORFEO

---

CARLO COLOMBO 2013

---

# OTI

---

CHI WING LO 2000/2009

---

# REVERSO

---

MASSIMO SCOLARI 2005



---

# ROMEO

---

ROBERTO LAZZERONI 2018

---

# ROUND

---

CARLO COLOMBO 2015

---

# TUMBLER

---

LAURA SILVESTRINI 2009

MOBILI E CASSETTONI  
SIDEBOARDS AND CHESTS OF DRAWERS

AEI.<sup>390</sup>ALFRED.<sup>396</sup>BULL.<sup>400</sup>  
CHARLOTTE.<sup>402</sup>CLAIRDELUNE.<sup>406</sup>  
CORIUM.<sup>408</sup>DECK.<sup>412</sup>DIA.<sup>414</sup>EON.<sup>416</sup>  
EONBUFFET.<sup>418</sup>FRAME.<sup>420</sup>INO.<sup>424</sup>  
JUPITER.<sup>428</sup>LIA.<sup>430</sup>MOORE.<sup>432</sup>  
MYO.<sup>438</sup>NARCISSE.<sup>440</sup>NEA.<sup>442</sup>NYN.<sup>444</sup>  
OLI2016.<sup>446</sup>ORIGAMI.<sup>450</sup>ORO.<sup>454</sup>  
OSCAR.<sup>458</sup>PING.<sup>460</sup>RIFT.<sup>462</sup>  
THECABINETOFMEMORIES.<sup>464</sup>  
TOO.<sup>470</sup>TOWN.<sup>472</sup>VENUS.<sup>480</sup>YANG.<sup>482</sup>

---

**AEI**

---

CHI WING LO 2011/2018



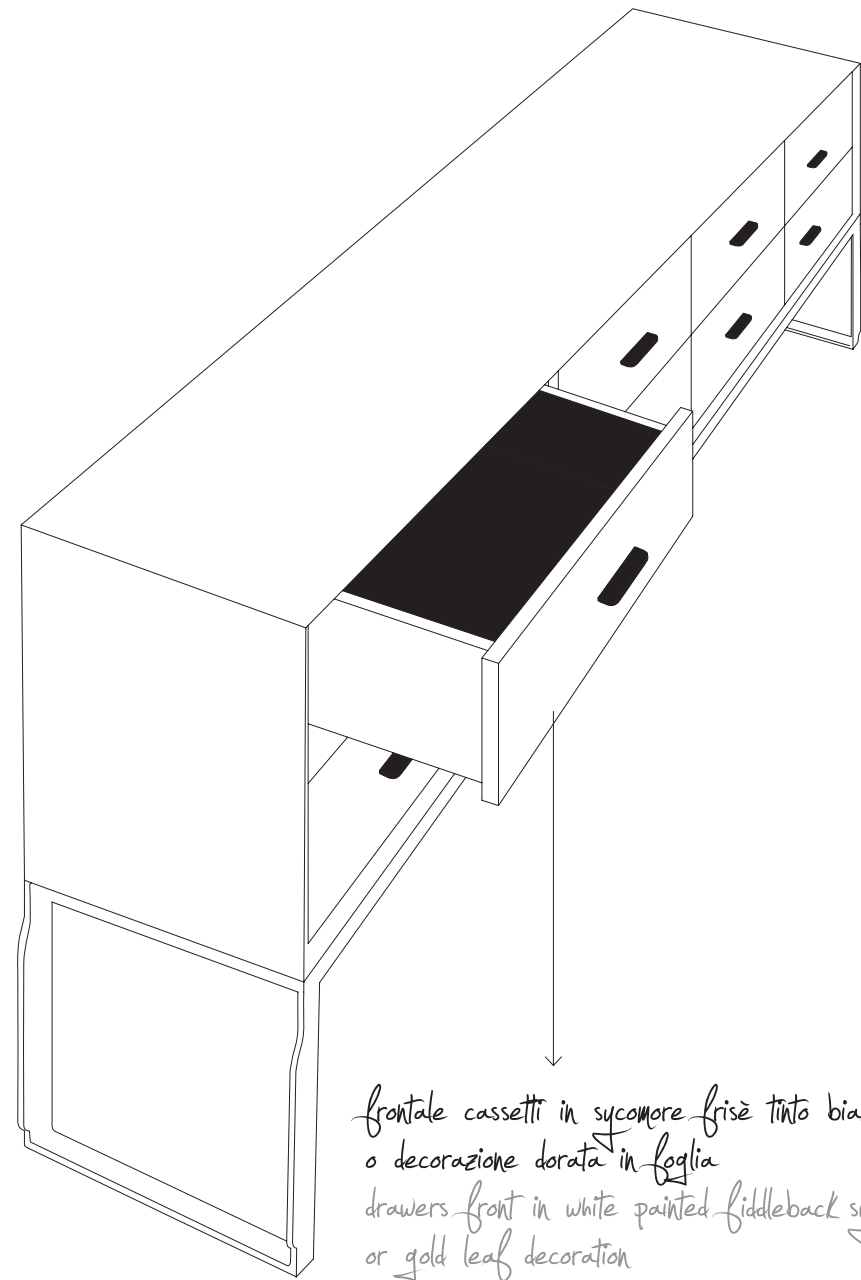

frontale cassetti in sycamore frisé tinto bianco  
o decorazione dorata in foglia  
drawers front in white painted fiddleback sycamore  
or gold leaf decoration

---

# ALFRED

---

CENTRO RICERCHE GIORGETTI 2018



---

# BULL

---

ROBERTO LAZZERONI 2014

---

# CHARLOTTE

---

CARLO COLOMBO 2018



---

# CLAIR DE LUNE

---

DESIGN MVW 2013

---

# CORIUM

---

UMBERTO ASNAGO 2013



---

# DECK

---

ROSSELLA PUGLIATTI 2015

---

# DIA

---

CHI WING LO 2012

independent drawer opening thanks to arnite spacers

---

# EON BUFFET

---

CHI WING LO 2008

---

# FRAME

---

CARLO COLOMBO 2017



---

INO

---

CHI WING LO 2011



interno disponibile in  
Sycamore frisé tinto bianco  
o decorazione dorata in foglia  
internal part available in  
white painted Fiddleback Sycamore  
or gold leaf decoration

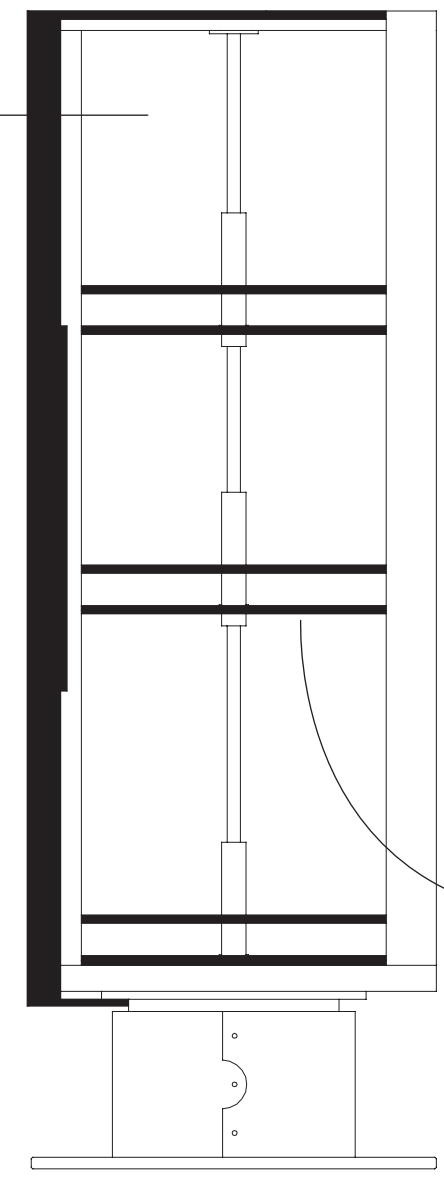

vassoi girevoli  
regolabili in altezza  
e piano in cristallo con luci led  
revolving trays  
that can be regulated in height  
with glass tops and led lights

---

# JUPITER

---

MASSIMO SCOLARI 1997

LIA

CHI WING LO 1995/2012

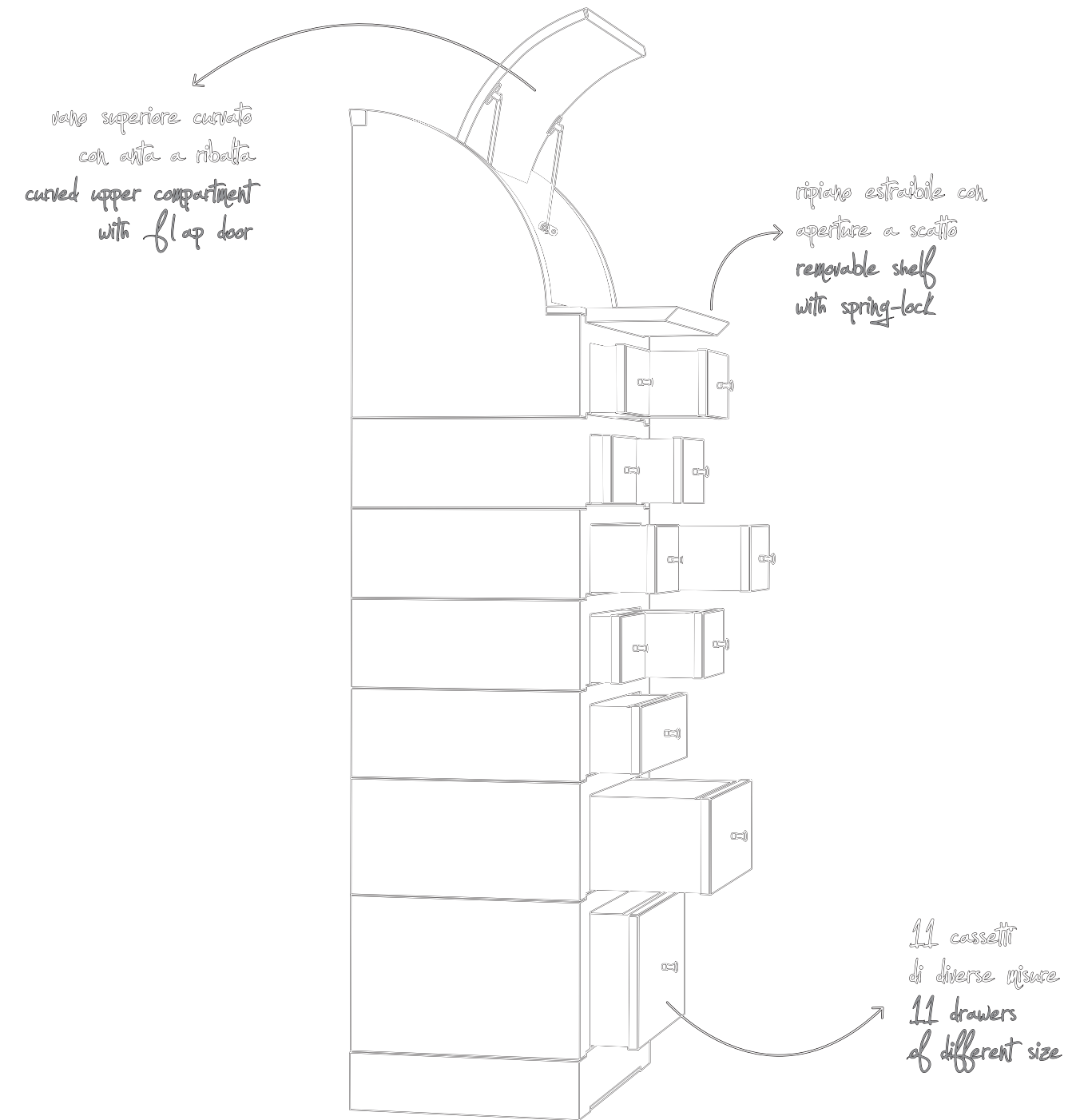

---

# MOORE

---

ROBERTO LAZZERONI 2015/2016





---

MIYO

---

CHI WING LO 2012



---

NEA

---

CHI WING LO 2010

---

NYN

---

CHI WING LO 1995/2012

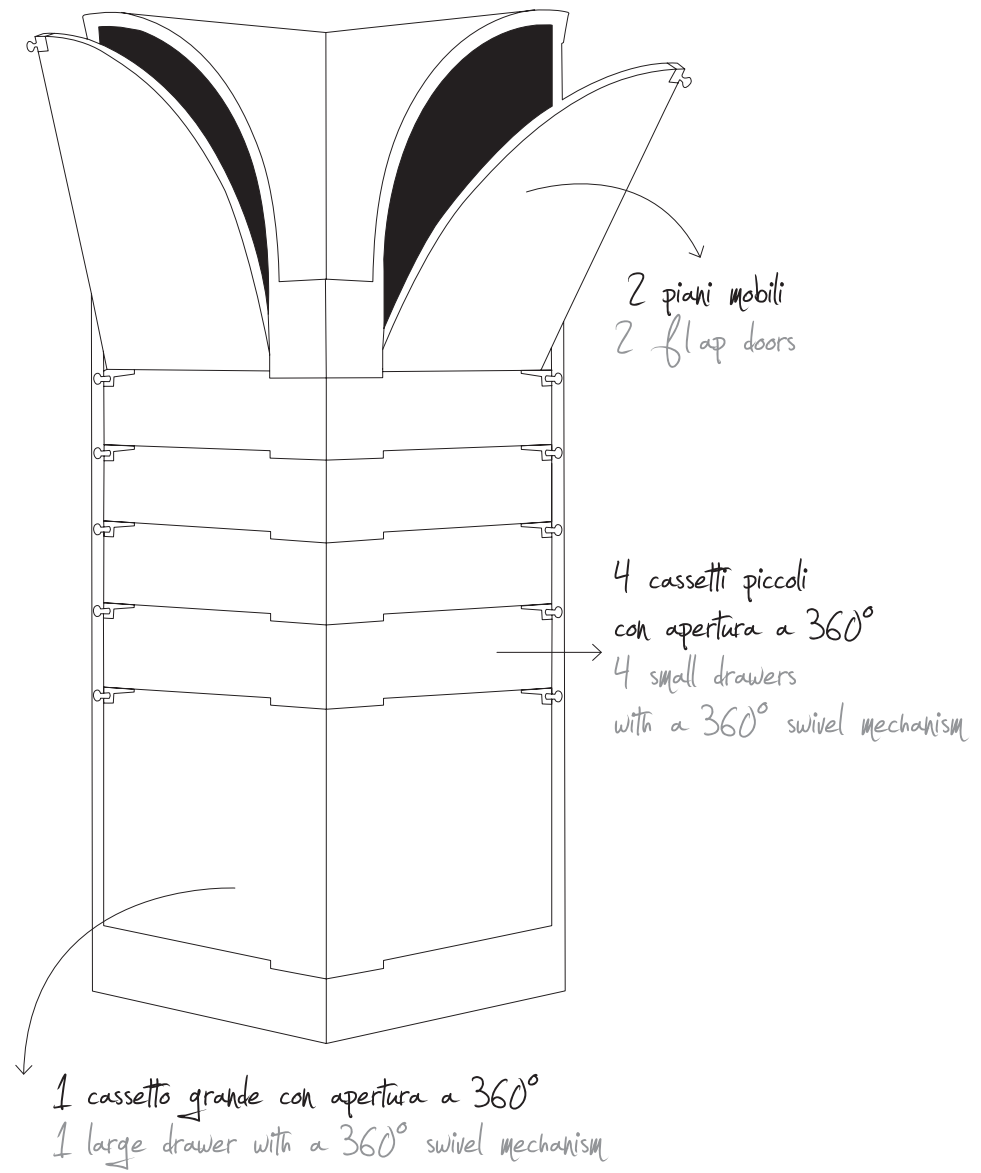

---

# OLI 2016

---

CHI WING LO 1995/2016



---

# ORIGAMI

---

MASSIMO CASTAGNA 2013

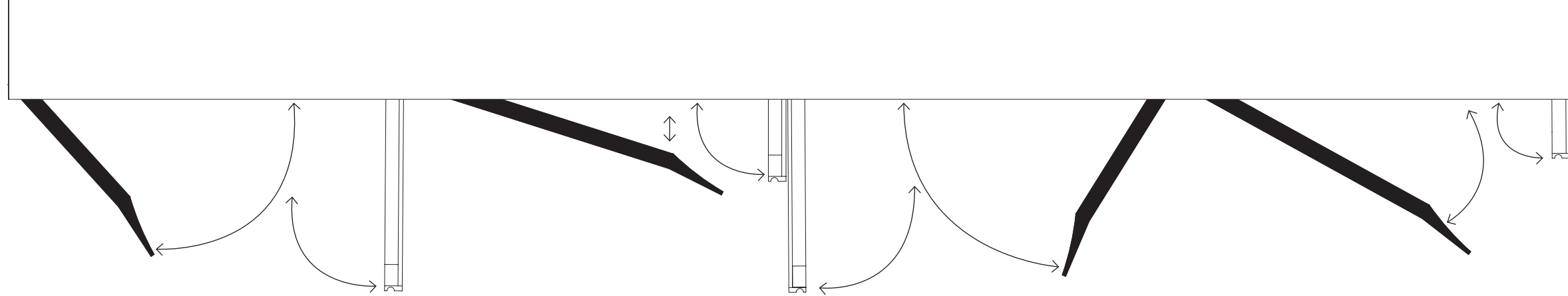

facciate con ante sovrapposte. anta esterna in eucalipto affumicato, anta interna in legno o vetro o cuoio  
front parts with overlapping doors. external door in smoked eucalyptus, internal one in wood or glass or saddle leather

---

ORO

---

CHI WING LO 2012

1 specchio circolare regolabile nell'inclinazione, con inserto ingranditore e luce  
1 adjustable tilt round mirror, with magnifying insert and light

17 cassetti frontali di 3 differenti dimensioni  
17 frontal drawers of 3 different sizes

1 secrétaire 1 hidden glove box

1 anta a contenitore  
1 storage door

3 cassetti laterali  
3 side drawers

1 calzascarpe 1 shoehorn

1 vano inferiore portascarpe 1 lower space for shoes

ORO

456  
457

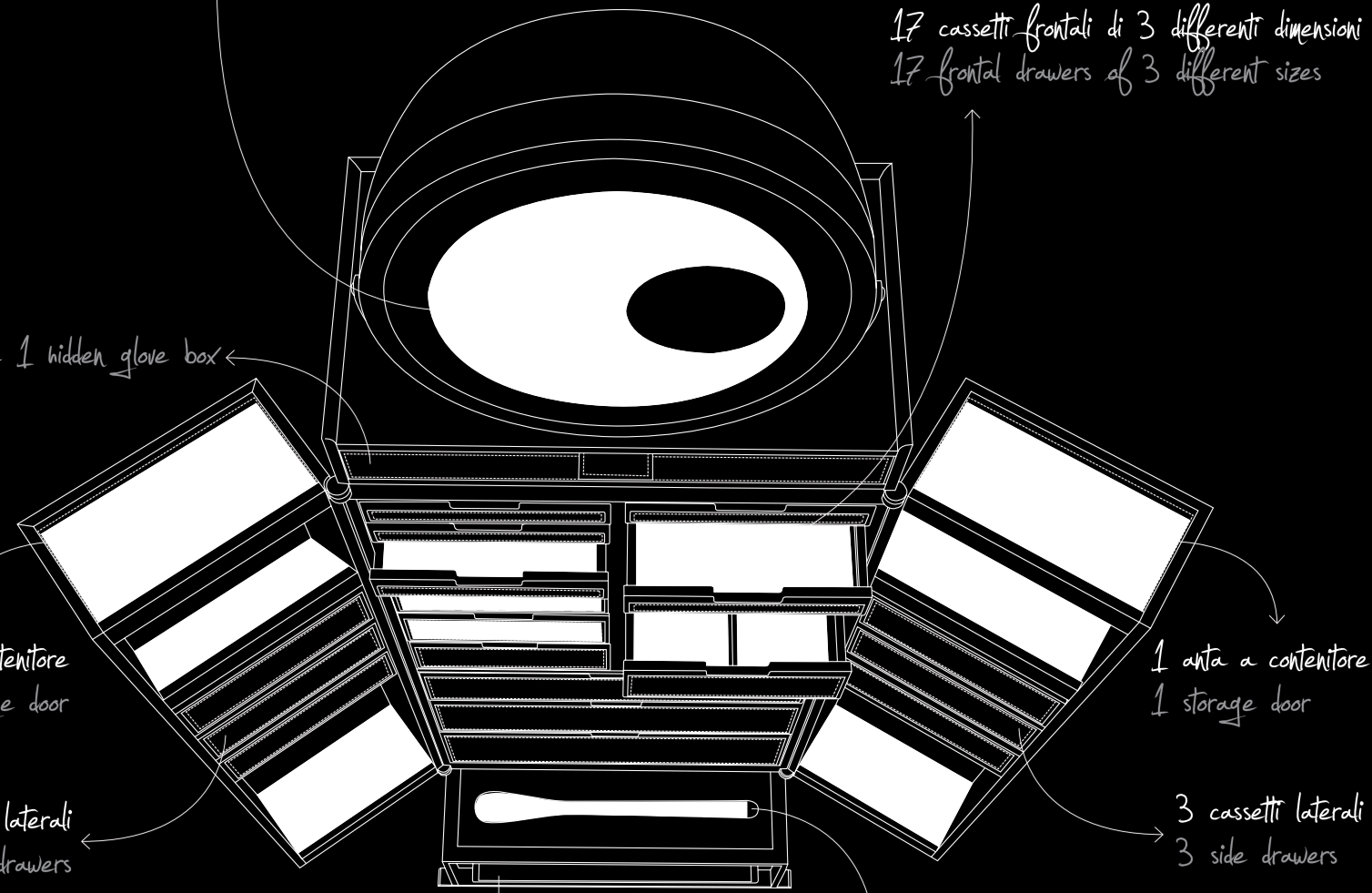

---

# OSCAR

---

LAURA SILVESTRINI 2011

---

# PING

---

DESIGN MVW 2013

---

# RIFT

---

GIANCARLO BOSIO E CENTRO RICERCHE GIORGETTI 2017

---

# THE CABINET OF MEMORIES

---

CHI WING LO 2018

—  
—

—  
466  
467  
—



---

# TOO

---

UMBERTO ASNAGO 2018

---

# TOWN

---

CARLO COLOMBO 2014/2018







---

# VENUS

---

ROBERTO LAZZERONI 2014

---

**YANG**

---

DESIGN MVW 2013

---

482  
483

---

---

OPEN-AIR

---

APSARASOFA<sup>486</sup>

GEACHAIR<sup>492</sup>. GEASMALL

ARMCHAIR<sup>494</sup>. GEASOFA<sup>498</sup>

GEABEACHLOUNGER<sup>502</sup>

GEATABLE<sup>504</sup>. GEACOFFEE

TABLE<sup>508</sup>. GEAPARASOL<sup>510</sup>

GEALAMP<sup>512</sup>. GEATRAY<sup>514</sup>

GEACANDLE-HOLDER<sup>516</sup>

OPEN-AIR

---

# APSARA

---

LUDOVICA + ROBERTO PALOMBA 2017





OPEN-AIR

---

GEA

---

CHI WING LO 2017

OPEN-AIR

---

**GEA**

---

CHI WING LO 2017



OPEN-AIR

---

**GEA**

---

CHI WING LO 2017



OPEN-AIR

---

**GEA**

---

CHI WING LO 2017

---

502  
503

---

OPEN-AIR

---

**GEA**

---

CHI WING LO 2017



OPEN-AIR

---

# GEA

---

CHI WING LO 2017

OPEN-AIR

---

# GEA

---

CHI WING LO 2017



OPEN-AIR

---

**GEA**

---

CHI WING LO 2017

---

512

513

---

OPEN-AIR

---

**GEA**

---

CHI WING LO 2017

OPEN-AIR

---

**GEA**

---

CHI WING LO 2017



GIORGETTI



GIORGETTI SPA  
I 20821 Meda (MB)  
Via Manzoni 20  
tel +39.0362.75275  
fax +39.0362.75575  
giorspa@giorgetti.eu  
www.giorgetti.eu

GIORGETTI ATELIER  
I 20122 Milano  
Via Serbelloni 14  
tel +39.02.99372000  
atelier@giorgetti.eu

GIORGETTI ATELIER  
B 2000 Antwerpen  
Britselei 16  
tel +32.3.3361694  
fax +32.3.3361697  
atelier@giorgettiantwerp.be  
www.giorgetti.eu

Giorgetti GmbH Deutschland  
D 50672 Köln  
Kaiser-Wilhelm-Ring 30-32  
tel +49.0221.12071850  
fax +49.0221.12071852  
info@giorgetti.de  
www.giorgetti.de

GIORGETTI USA INC  
New York, NY  
tel +1.212.8893261  
info@giorgettiusa.com  
www.giorgettiusa.com

GIORGETTI ASIA PTE LTD  
208575 Singapore  
342B King George's Avenue  
King George's Building  
tel +65.6407.1555  
www.giorgetti.eu

IDEAZIONE E COORDINAMENTO  
Centro Ricerche e Immagine Giorgetti

FOTOGRAFIE  
Marco Beck Peccoz  
Sergio Chimenti  
Pesarini e Michetti  
Armando Rebatto  
Salvati e Salvati  
Alberto Tagliabue  
Max Zambelli

FOTOLITO  
Articrom

© giorgetti spa 2018  
giorgetti.eu

I diritti delle fotografie sono di proprietà  
degli autori e della Giorgetti S.p.A.  
È vietata la riproduzione  
anche solo parziale.  
Gorgetti S.p.A. si riserva il diritto di  
apportare le modifiche necessarie e  
migliorative ai prodotti qui illustrati,  
in qualsiasi momento e  
senza obbligo di preavviso.  
Le finiture riportate nella legenda dei  
singoli prodotti si riferiscono alla collezione  
Gorgetti aggiornata a Aprile 2018.

*All photos are copyrighted  
material and all rights are reserved  
to the respective photographer  
and to Giorgetti S.p.A.  
Photo reproduction  
in whole or in part is prohibited.  
Gorgetti S.p.A. reserves the right to make  
any necessary modifications and  
improvements to the products in these  
depictions, at any time and without  
prior notification.  
The finishes specified in the legend of  
the single products refer to the Giorgetti  
collection up-to-date as of April 2018.*

